

London Styling Chair Specifications Sheet



SKIN+ACT

Toll Free: 1.800.418.0830

www.skinact.com
www.spaandequipment.com

International: 818.834.6640

NOTICE

No part of this document may be photocopied, reproduced, or translated into any other language without prior written consent of Spa and Equipment/SkinAct.

The information in this document is subject to change without notice at any time and should not be construed as a commitment by Spa and Equipment/SkinAct.

Spa and Equipment/SkinAct assumes no responsibility for any errors that may be in this document, nor does it make expressed or implied warranty with regard to this material, including, but not limited to, the implied warranties of merchantability and fitness for a particular purpose.

Spa and Equipment/SkinAct shall not be liable for incidental or consequential damages arising out of the furnishing, performance, or use of this document and the program material which it describes.

SKIN+ACT

Toll Free: 1.800.418.0830	www.skinact.com www.spaandequipment.com	International: 818.834.6640
---------------------------	--	-----------------------------

Measurements



Measurements

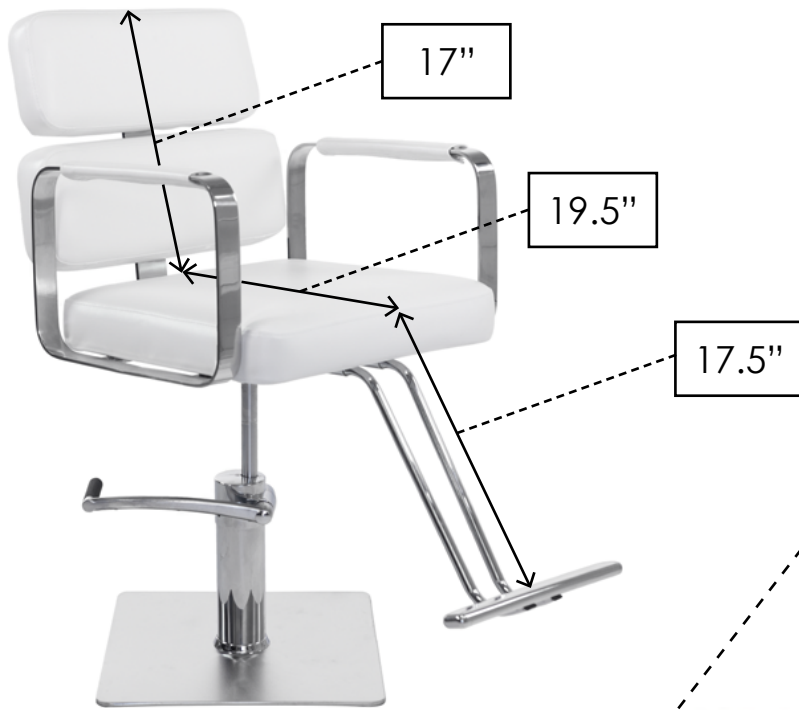



Highlights

Key Features:

- Hydraulic foot pump for easy raising and lowering
- Rotates 360 degrees around
- Top-grade vinyl feels like real leather
- Cushions made of high-density foam for extra comfort and longer duration of use
- Sturdy construction
- Bearing pressure up to 450 lbs

Detailed unit dimensions:

- Full length from back to front: 36"
- Width of the seat cushion: 19.5"
- Depth of the seat cushion: 19.5"
- Width from arm rest to arm rest: 23"
- Height from ground to top of seat cushion: 19.5" - 25.5"
- CHAIR BASE ONLY Dimensions: 17" x 17"

* All height measurements are from ground to top of cushion *

** All measurements have a 0.5 to 1 inch tolerance **

Warranty Information:

1-year warranty